



## REMOTE INDICATORS – CONVENTIONAL

# SENSOMAG REMOTE FIRE LED



SENSOMAG  
REMOTE FIRE LED

### DESCRIPTION

SensoMAG LED is a fire remote indicator with 1 input. The device repeats the status of 1 or several automatic fire detectors (up to 3 SensoMAG detectors in series).

The remote indicator operates with the range of SensoMAG conventional detectors.

### FEATURES

- 2 Year Warranty
- Built-in Current Limit
- Large, Bright Red LED
- Modern Aesthetic Design





# REMOTE INDICATORS – CONVENTIONAL

## SENSOMAG REMOTE FIRE LED

### TECHNICAL SPECIFICATIONS

Current consumption in activated state	30 mA
Wire Gauge for Terminals	2.5 mm <sup>2</sup>
Operating Temperature	-10°C to +60°C
Relative Humidity Resistance	(93 ± 3)% @ 40°C
Weight	±42 g
Material (plastic), Colour	ABS, White
Dimensions (mm)	85 x 85 x 20

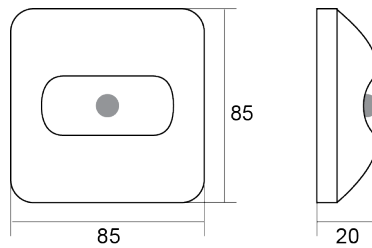

### CONNECTION DIAGRAM

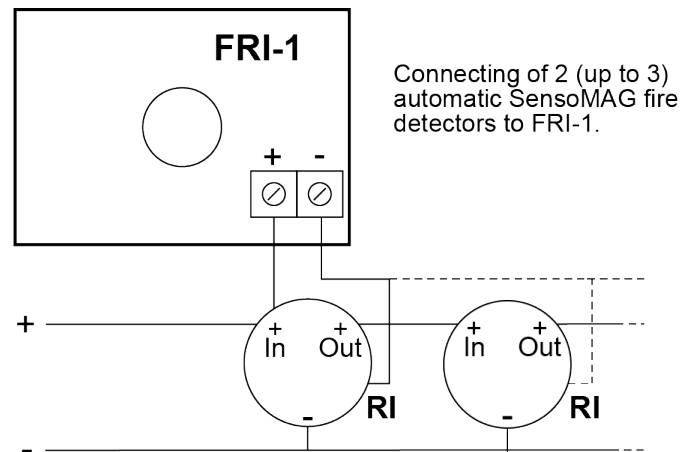
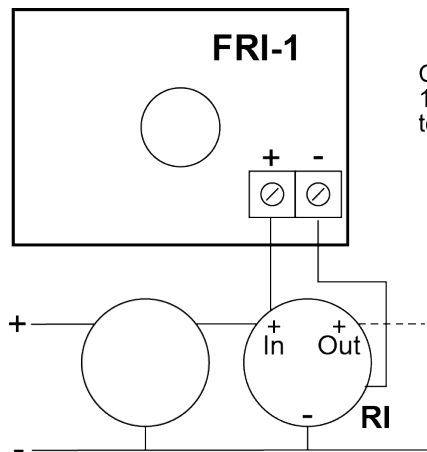

### ORDERING INFORMATION

Product Code	Product Description
TE-SensoMAG-LED	SensoMAG Remote Fire LED

DISCLAIMER: Although the contents of our product literature have been prepared with the greatest care, Technoswitch can accept no liability whatsoever for any direct or indirect damages of any kind that may arise due to either errors or omissions in them, or amendments to products or other specifications following publication.



**HEAD OFFICE — JOHANNESBURG**  
 Cussonia Park, 3 Ridge Road, Laser Park, Johannesburg T +27 (0)11 794 9144 E info@technoswitch.co.za  
**CAPE TOWN T +21 948 4575 DURBAN T +27 (0)31 266 8843**

[www.technoswitch.co.za](http://www.technoswitch.co.za)

Document: DS Sensomag-LED 201102 E & OE